

NOTES:

1. TANK IS MANUFACTURED TO ASTM-D-1998 STANDARD.
2. ALL DIMENSIONS ARE APPROXIMATE.

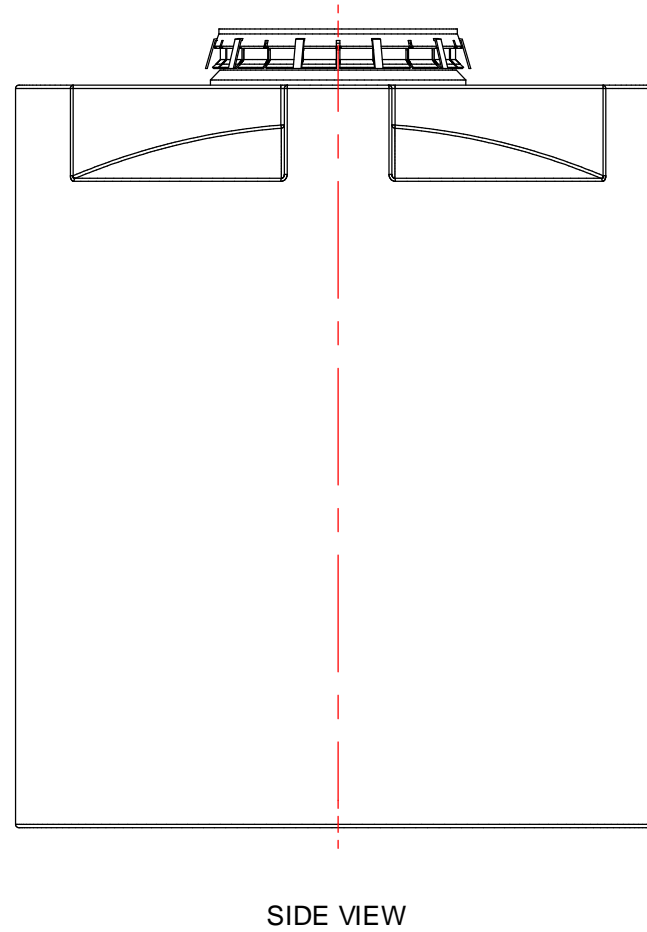

MATERIALS LIST		
ITEMS	DESCRIPTION	NOTES
A	VFA300CH VERTICAL TANK	
B	16" LID WITH LOCKING STRAP	

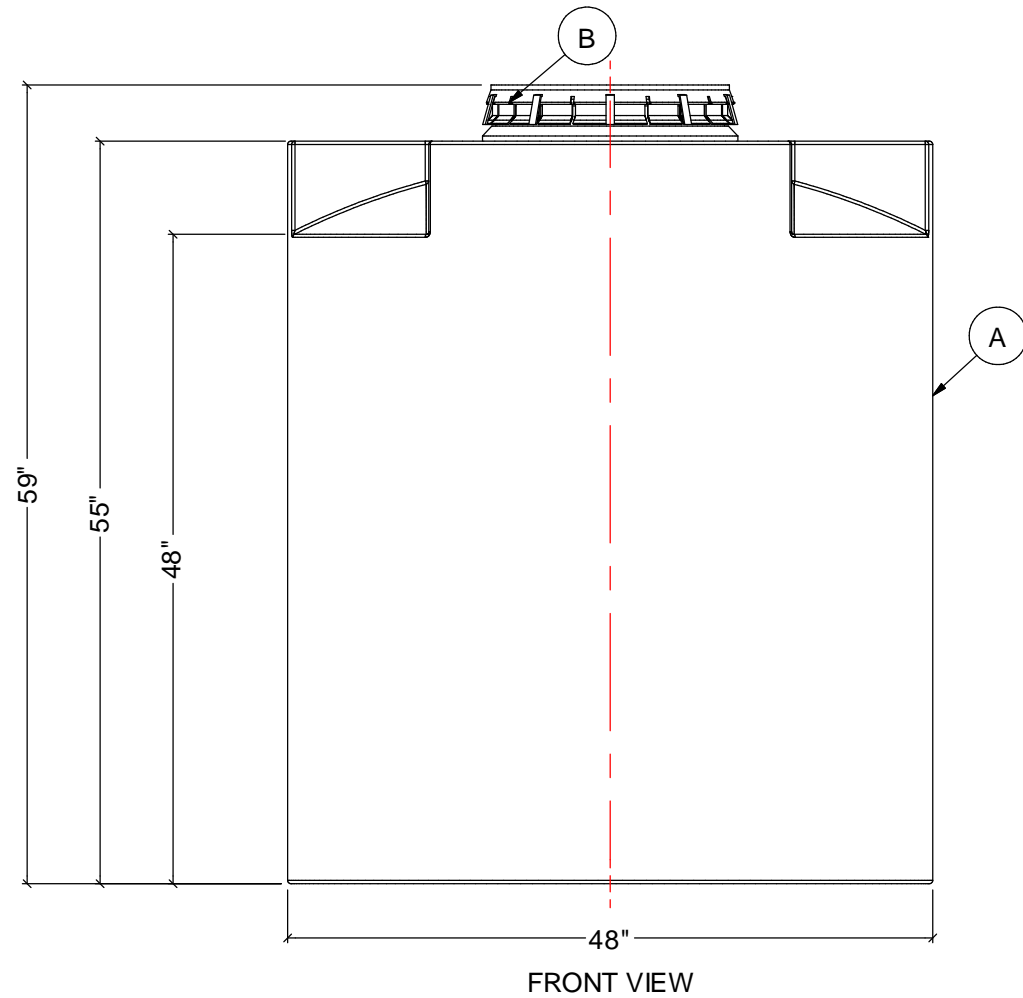
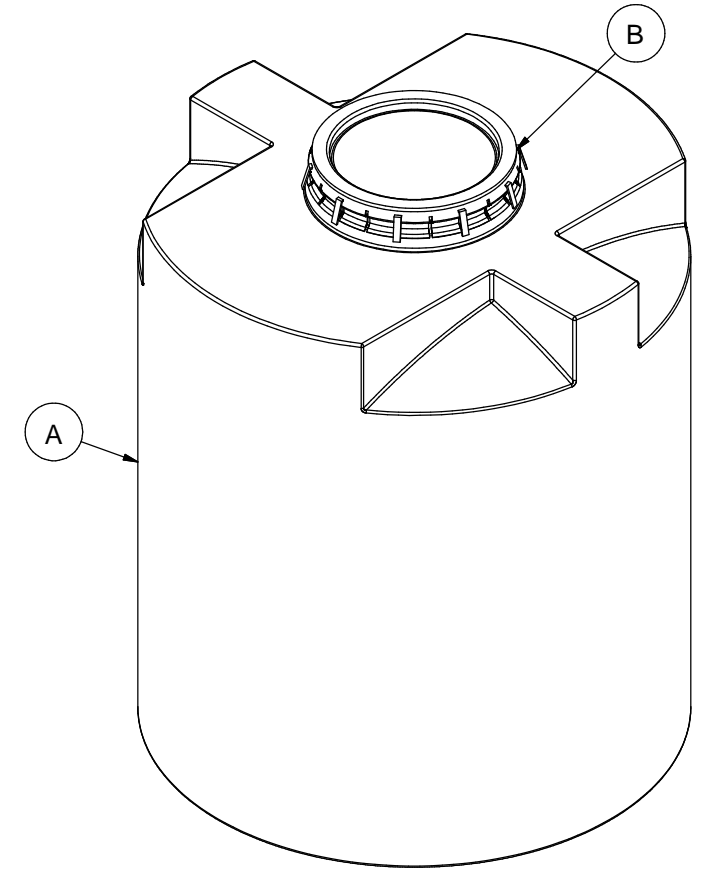

AGRICO PLASTIQUES
450-471-2772
WWW.AGRICOPLASTIQUES.COM

RÉSERVOIR VFA300CH

CAPACITÉ DE:
300 GALLONS IMPÉRIAUX
360 GALLONS US
1360 LITRES