

NOTES:

1. TANK IS MANUFACTURED TO ASTM-D-1998 STANDARD.
2. ALL DIMENSIONS ARE APPROXIMATE.

MATERIALS LIST		
ITEMS	DESCRIPTION	NOTES
A	VFA310 VERTICAL TANK	
B	16" LID WITH LOCKING STRAP	

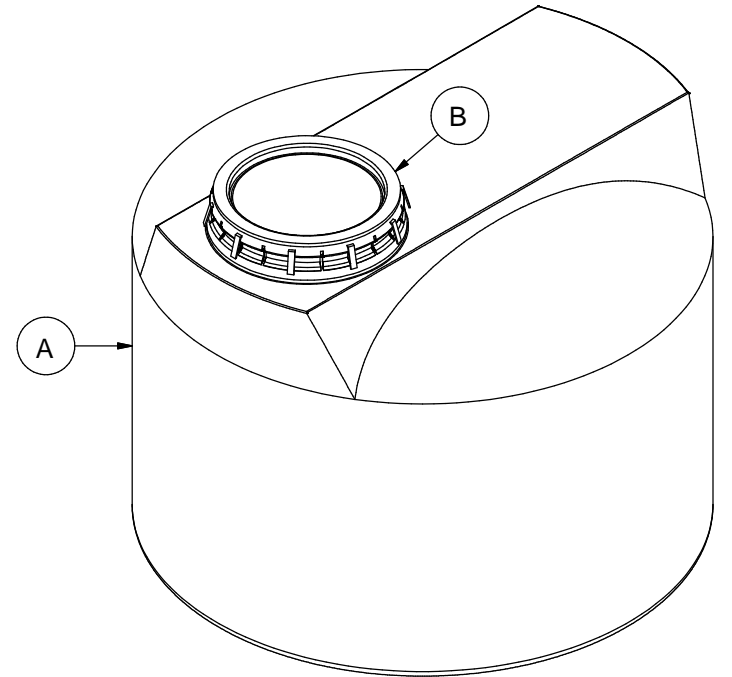
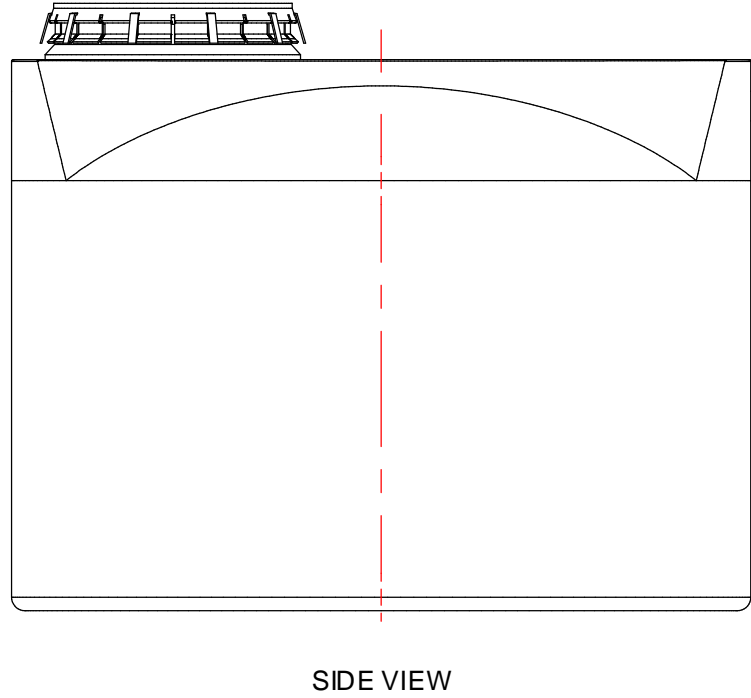
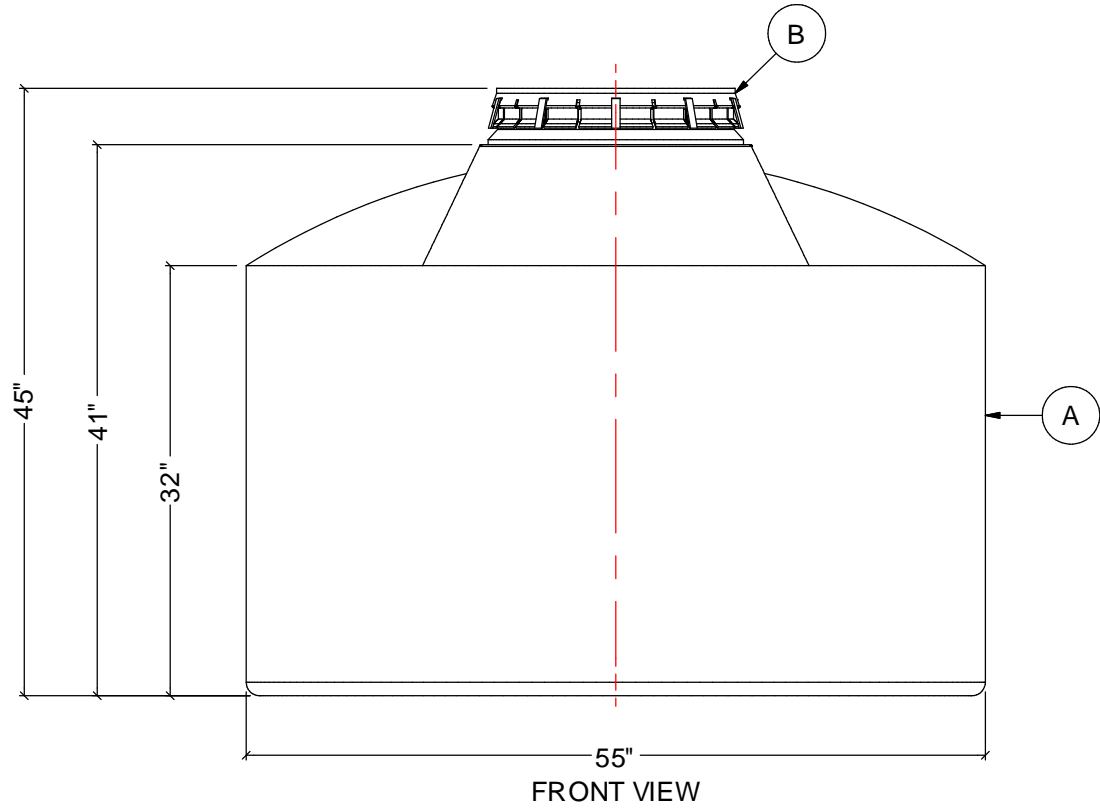

AGRICO PLASTIQUES
 450-471-2772

WWW.AGRICOPLASTIQUES.COM

RÉSERVOIR VFA310

CAPACITÉ DE:
 310 GALLONS IMPÉRIAUX
 372 GALLONS US
 1400 LITRES