

TOP VIEW

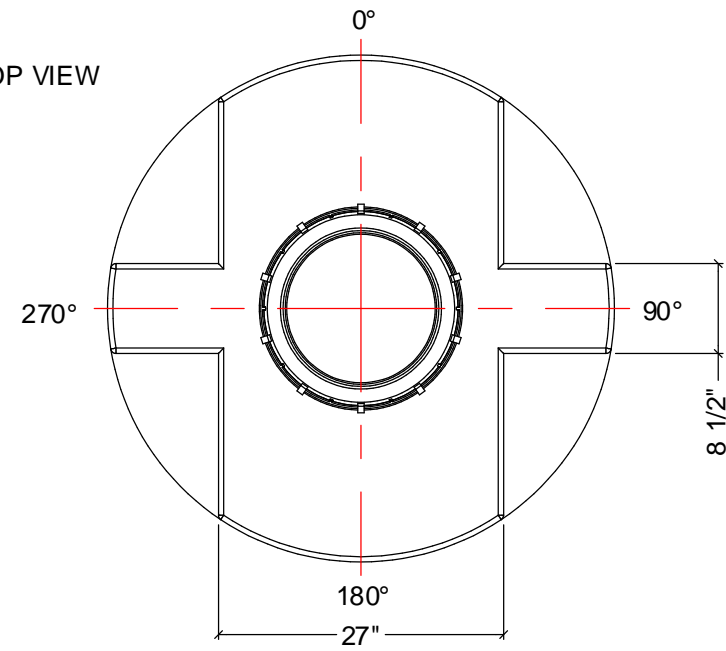

NOTES:

- 1. TANK IS MANUFACTURED TO ASTM-D-1998 STANDARD.
- 2. ALL DIMENSIONS ARE APPROXIMATE.

MATERIALS LIST		
ITEMS	DESCRIPTION	NOTES
A	VFA500CH VERTICAL TANK	
B	16" LID WITH LOCKING STRAP	

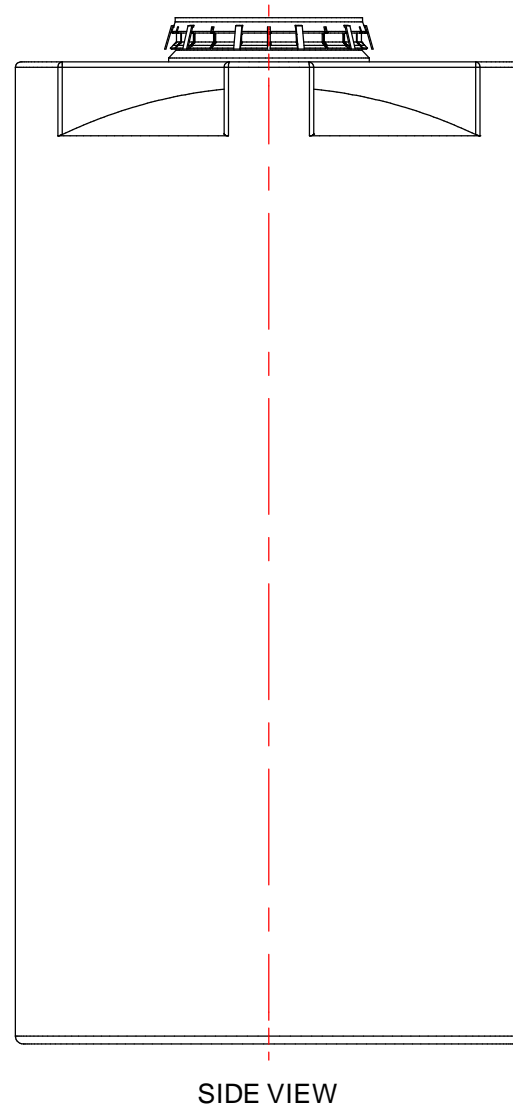
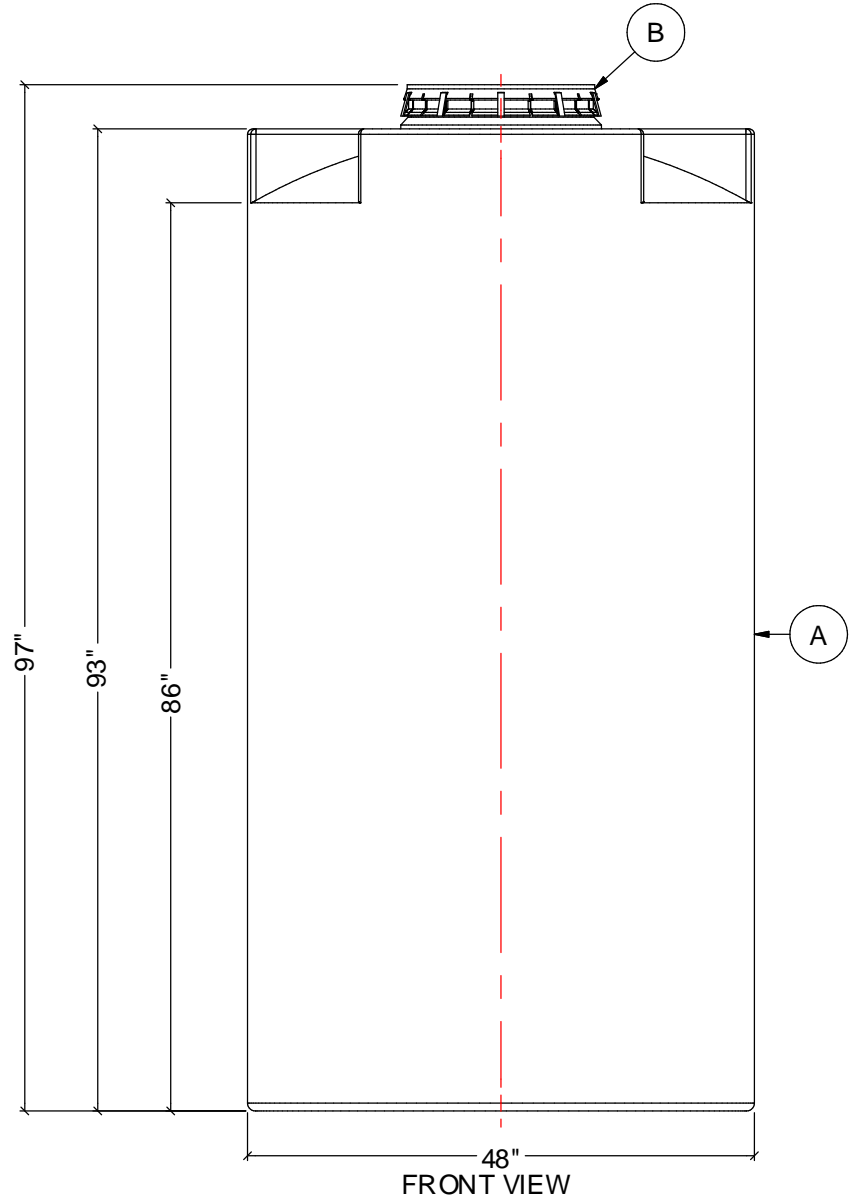

SIDE VIEW

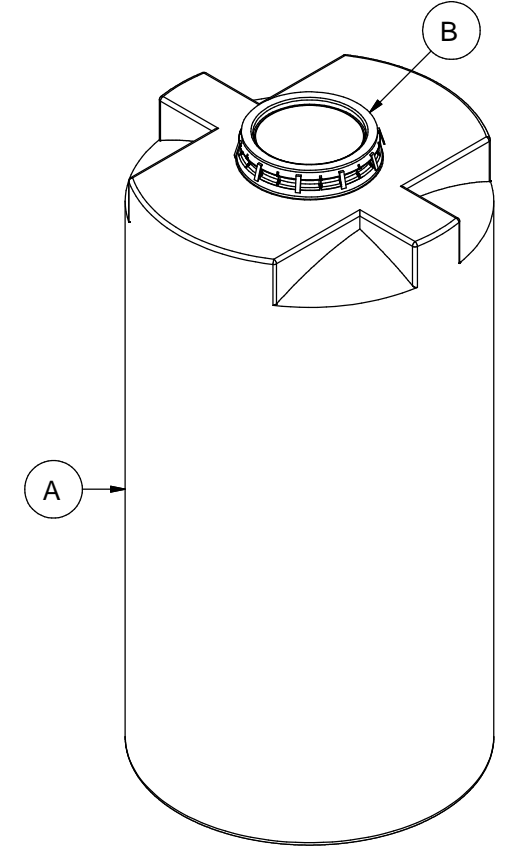

AGRICO PLASTIQUES
 450-471-2772
WWW.AGRICOPLASTIQUES.COM
 RÉSERVOIR VFA500CH
 CAPACITÉ DE:
 500 GALLONS IMPÉRIAUX
 600 GALLONS US
 2200 LITRES