

RÉSERVOIR VERTICAL OUVERT 60 GALLONS US

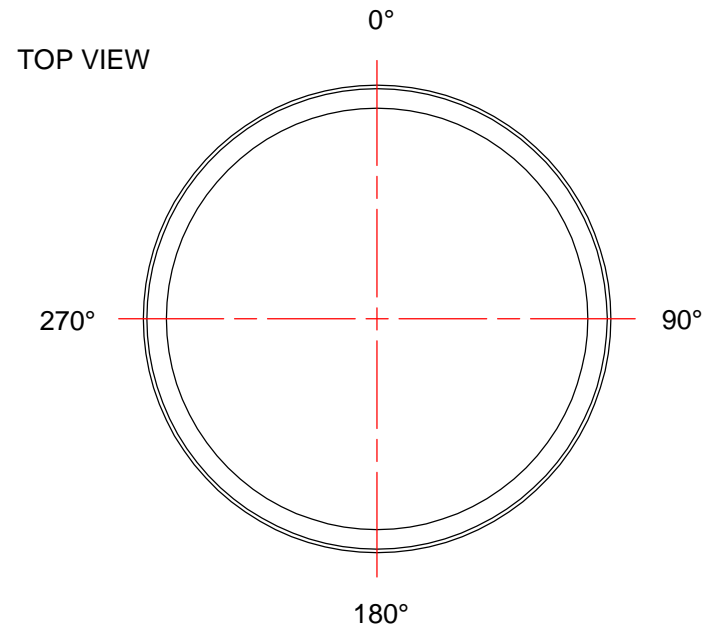

NOTES:

1. TANK IS MANUFACTURED TO ASTM-D-1998 STANDARD.
2. ALL DIMENSIONS ARE APPROXIMATE.

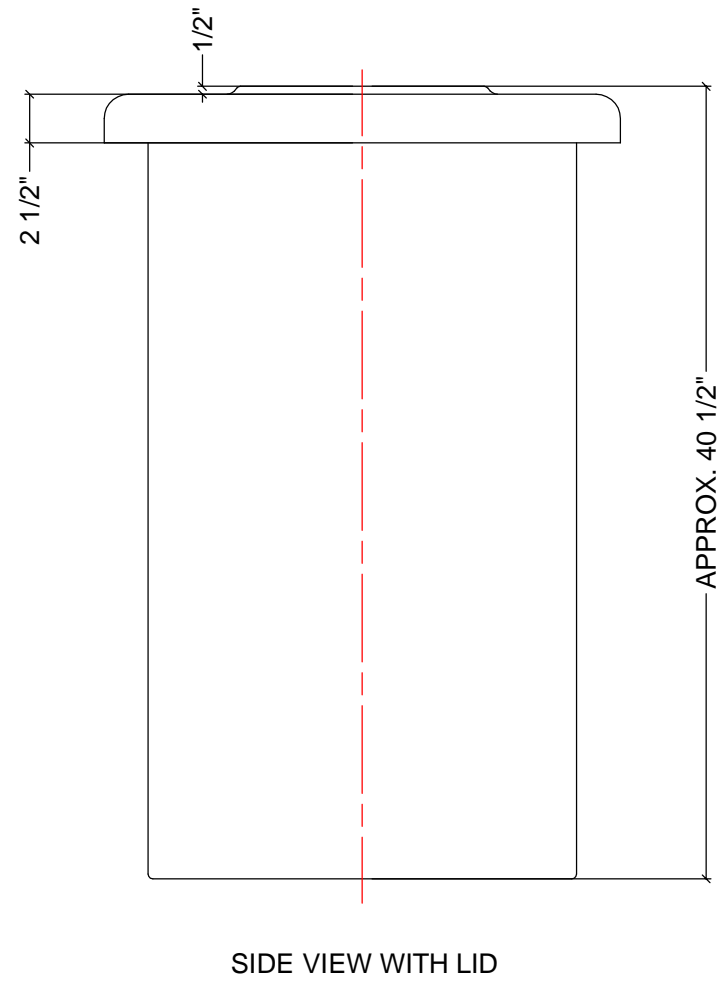
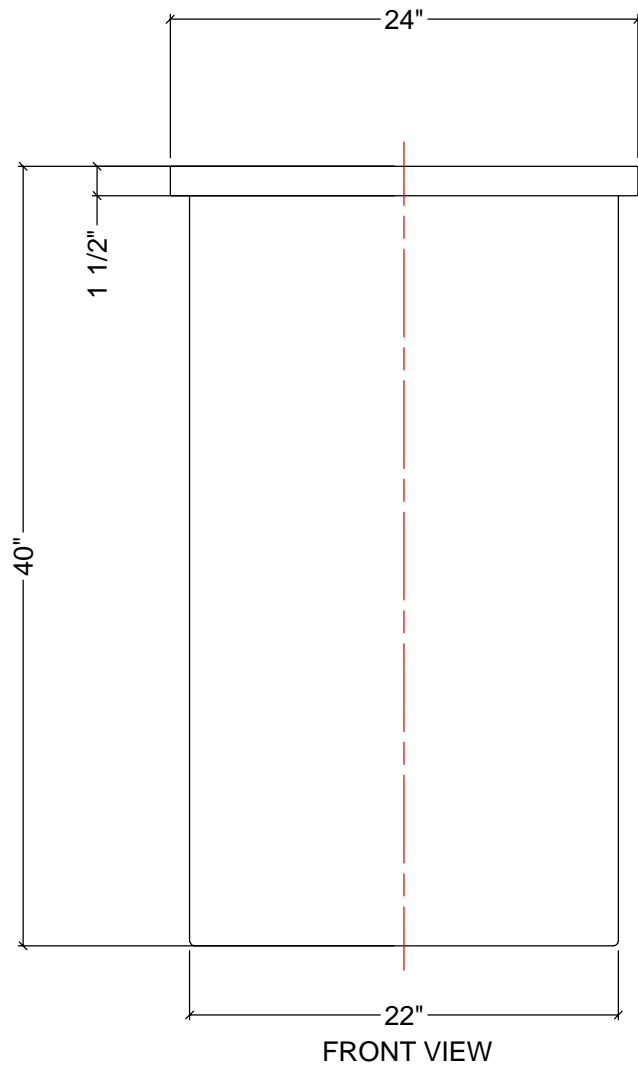
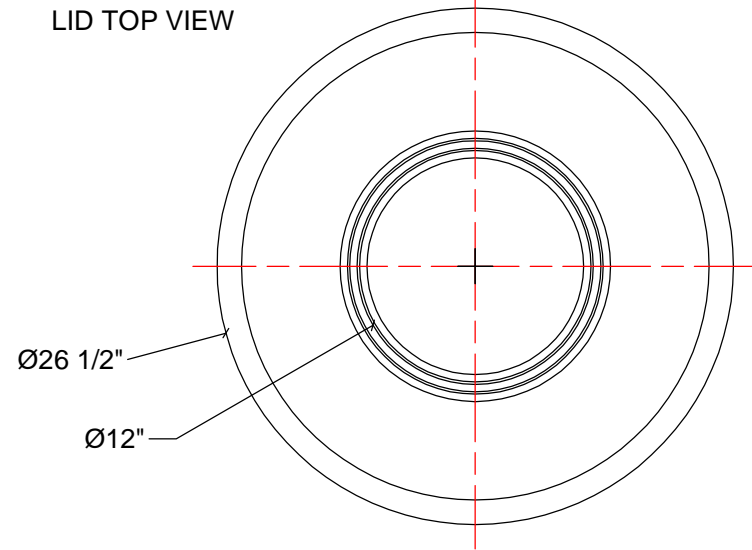

MATERIALS LIST		
ITEMS	DESCRIPTION	NOTES
A	OT5015 / OT5019 OPEN TOP TANK	
B	LID FOR OT50	

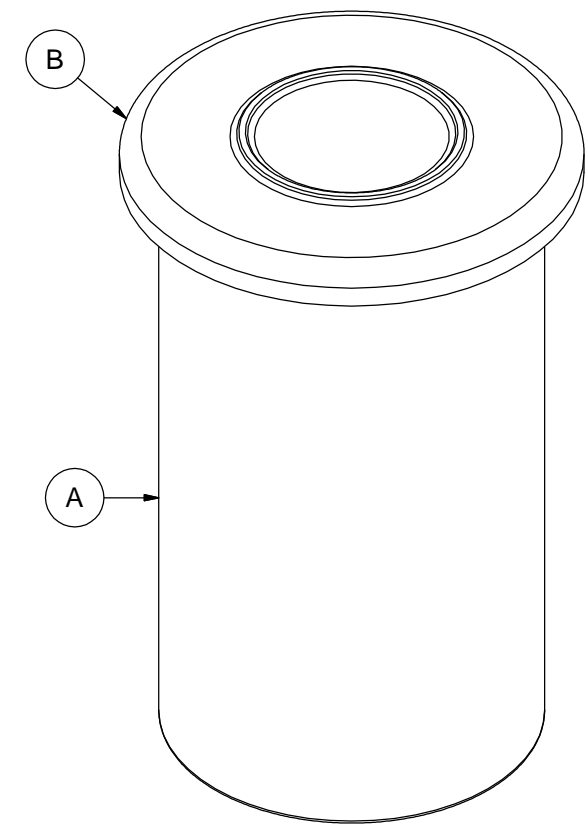

**AGRICO PLASTIQUES**  
 450-471-2772  
[WWW.AGRICOPLASTIQUES.COM](http://WWW.AGRICOPLASTIQUES.COM)  
 RÉSERVOIR OT5015 / OT5019  
 CAPACITÉ DE:  
 50 GALLONS IMPÉRIAUX  
 60 GALLONS US  
 227 LITRES