

TOP VIEW

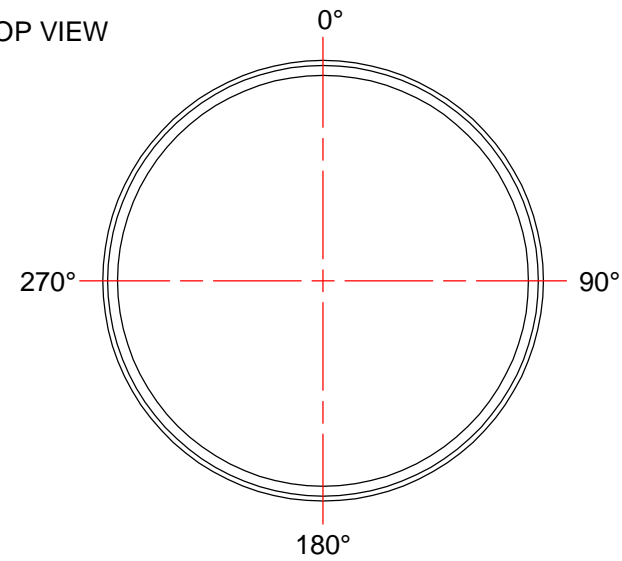

NOTES:

- 1. TANK IS MANUFACTURED TO ASTM-D-1998 STANDARD.
- 2. ALL DIMENSIONS ARE APPROXIMATE.

LID TOP VIEW

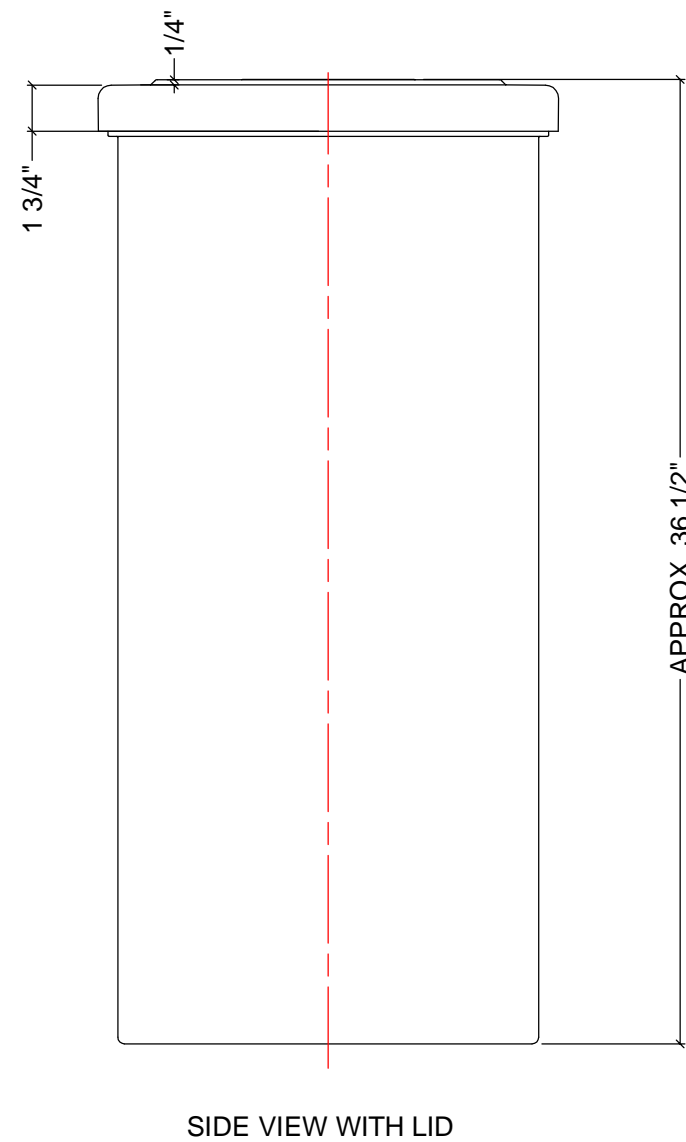
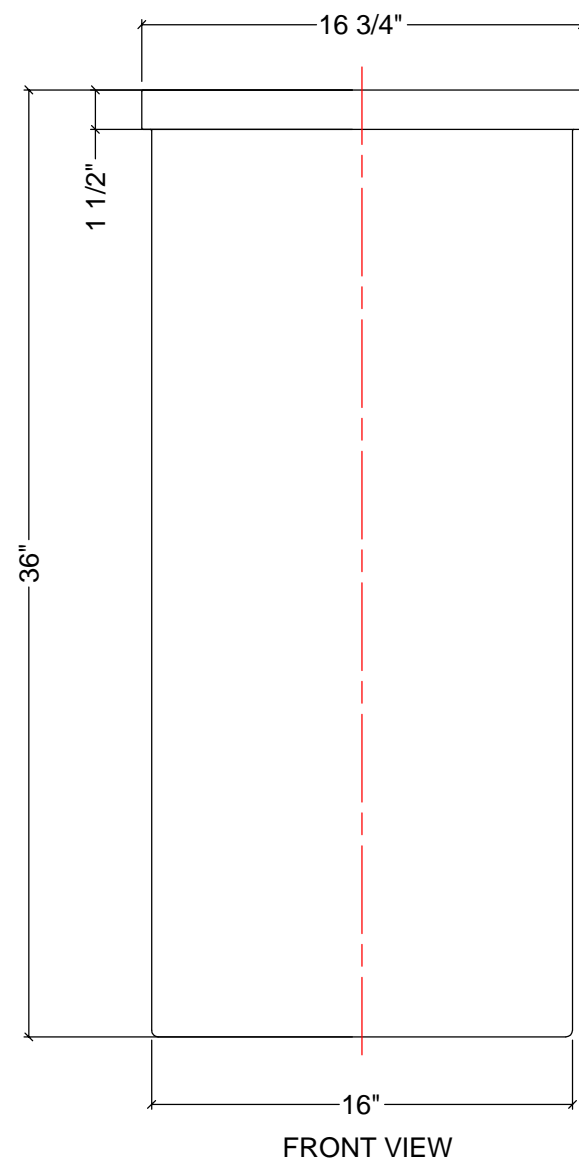
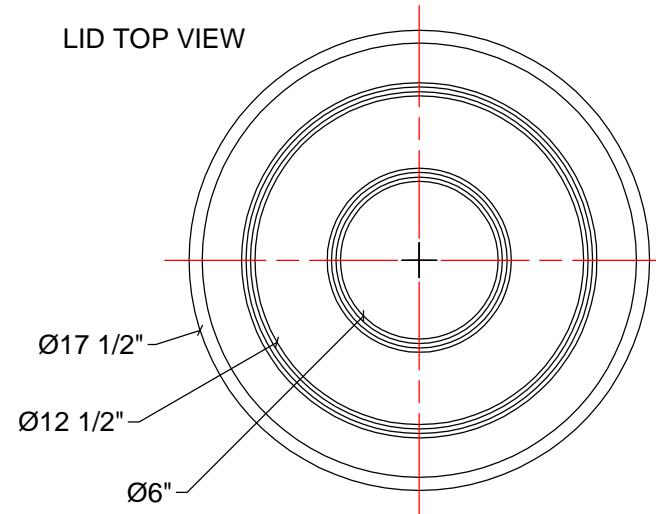

MATERIALS LIST		
ITEMS	DESCRIPTION	NOTES
A	OT-25 OPEN TOP TANK	
B	LID FOR OT-25	

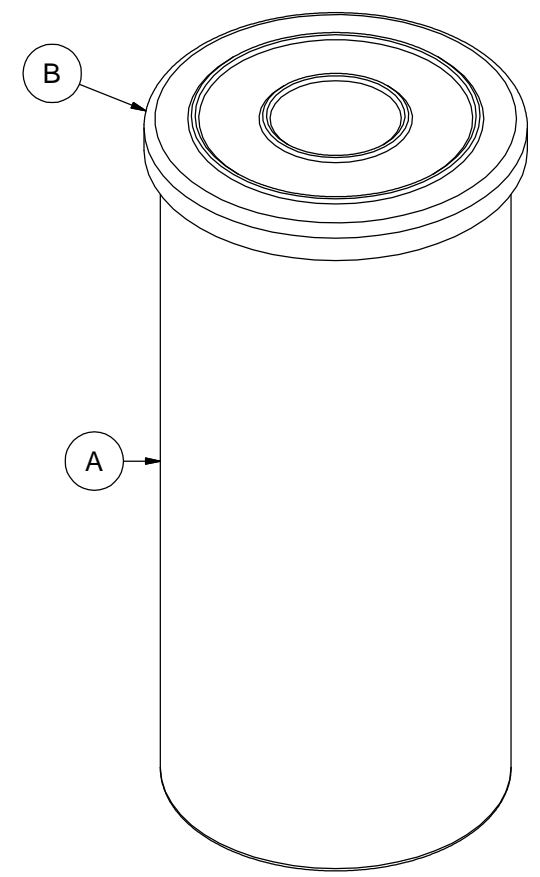

AGRICO PLASTIQUES
 450-471-2772
WWW.AGRICOPLASTIQUES.COM
 RÉSERVOIR OT-25
 CAPACITÉ DE:
 25 GALLONS IMPERIAUX
 30 GALLONS US
 114 LITRES