

NOTES:

1. TANK IS MANUFACTURED TO ASTM-D-1998 STANDARD.
2. ALL DIMENSIONS ARE APPROXIMATE.

LID TOP VIEW

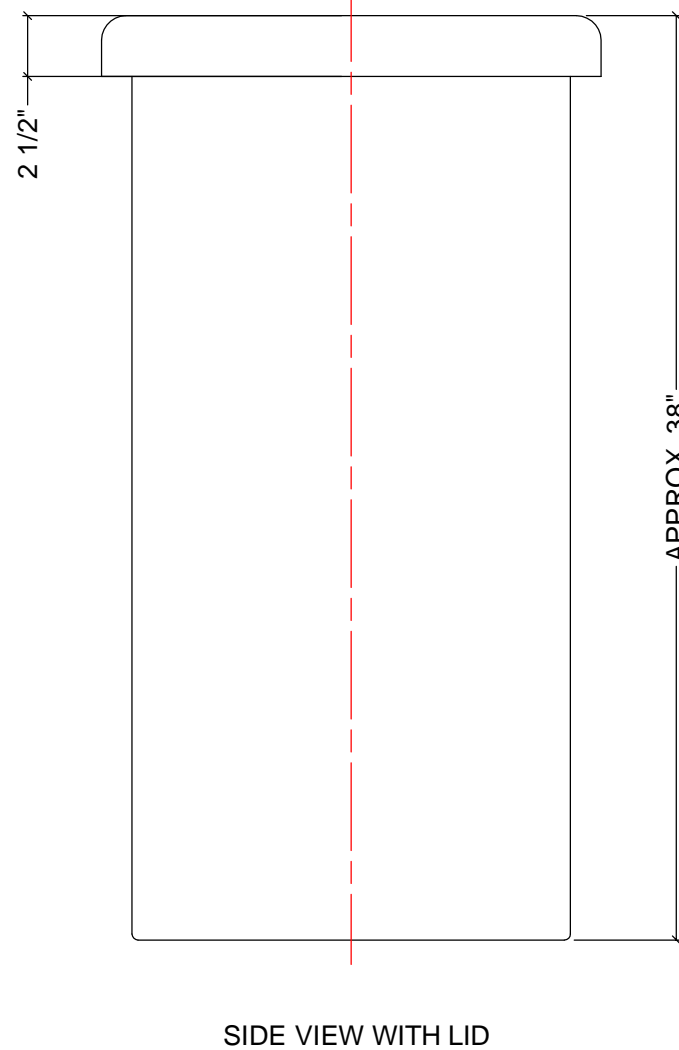
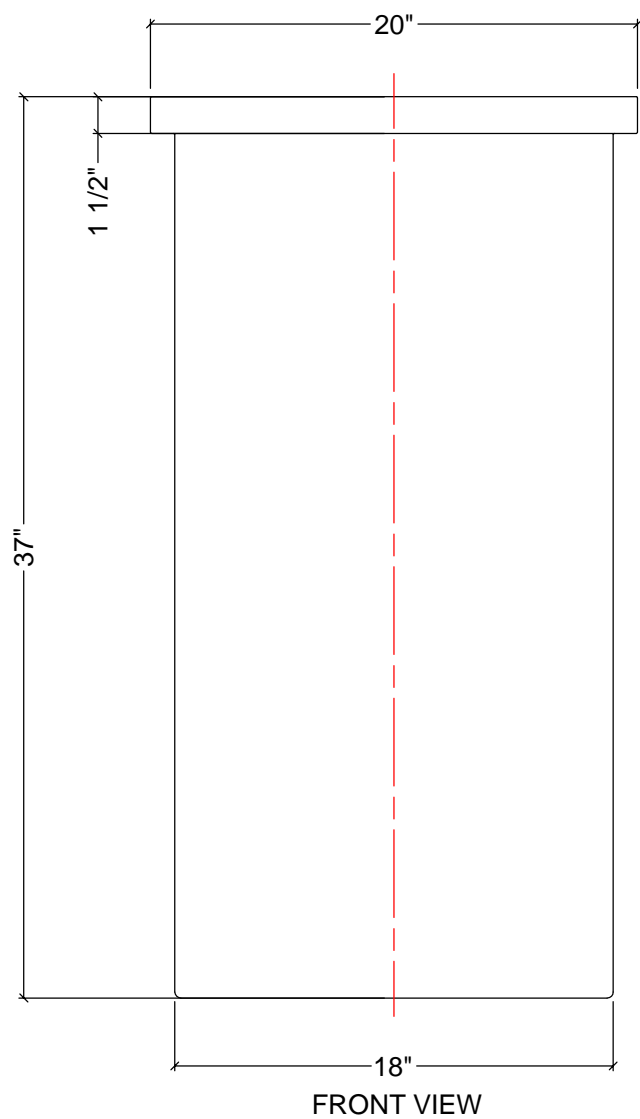
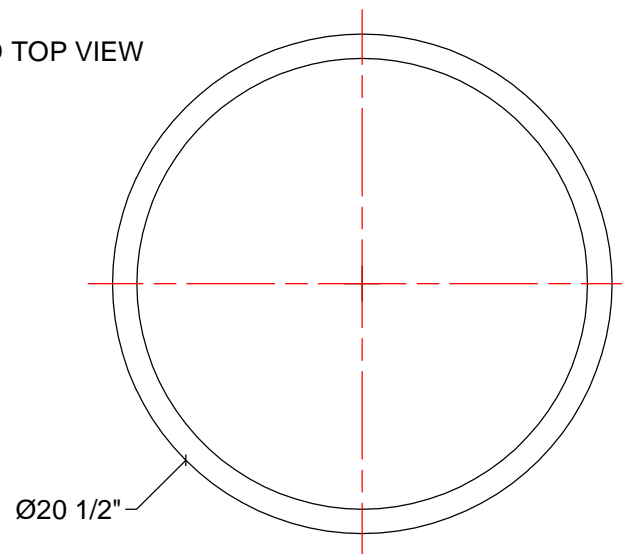

MATERIALS LIST		
ITEMS	DESCRIPTION	NOTES
A	OT-30 OPEN TOP TANK	
B	LID FOR OT-30	

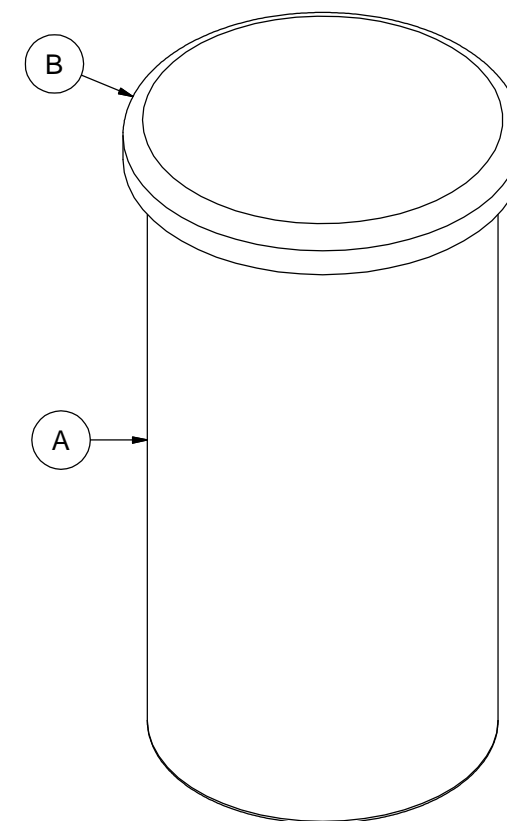

AGRICO PLASTIQUES
450-471-2772

WWW.AGRICOPLASTIQUES.COM

RÉSERVOIR OT-30

CAPACITÉ DE:
30 GALLONS IMPÉRIAUX
36 GALLONS US
136 LITRES