

NOTES:

1. TANK IS MANUFACTURED TO ASTM-D-1998 STANDARD.
2. ALL DIMENSIONS ARE APPROXIMATE.

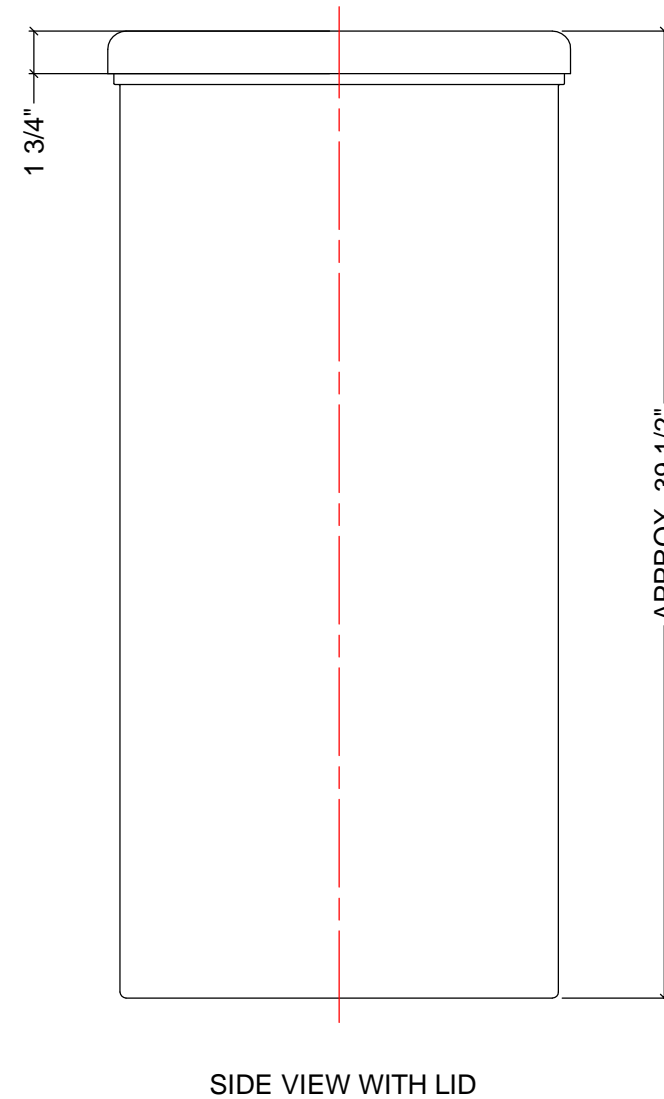

MATERIALS LIST		
ITEMS	DESCRIPTION	NOTES
A	OT-36 OPEN TOP TANK	
B	LID FOR OT-36	

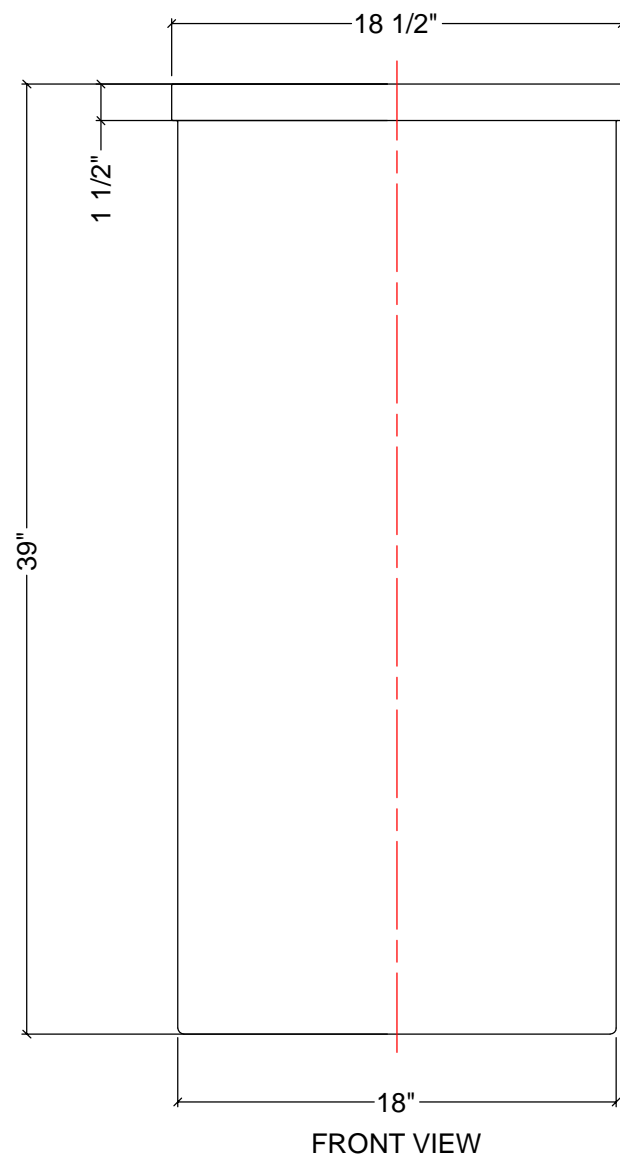
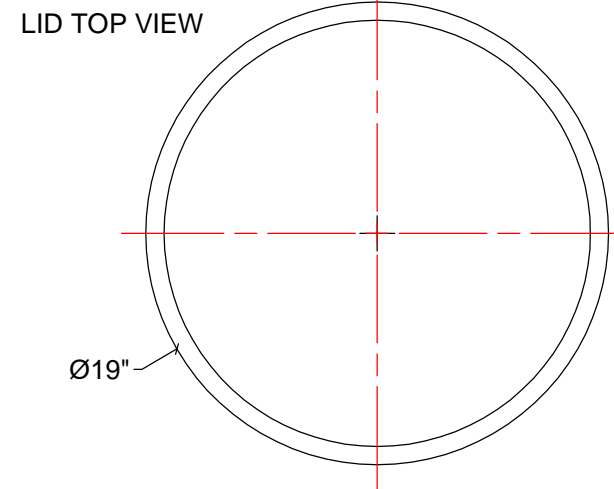
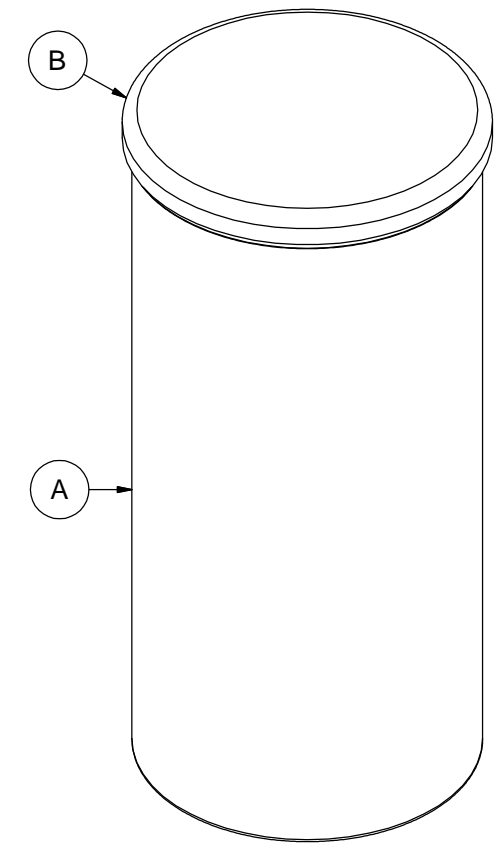

AGRICO PLASTIQUES
 450-471-2772
WWW.AGRICOPLASTIQUES.COM
 RÉSERVOIR OT36
 CAPACITÉ DE:
 36 GALLONS IMPÉRIAUX
 43 GALLONS US
 164 LITRES