

### MATERIALS LIST

ITEMS	DESCRIPTION	NOTES
A	IRD-90 SECONDARY CONTAINMENT BASIN	

**NOTES:**

1. TANK IS MANUFACTURED TO ASTM-D-1998 STANDARD.
2. TANK CAPACITY: 90 I.G. (430 L).
3. ALL DIMENSIONS ARE APPROXIMATE.

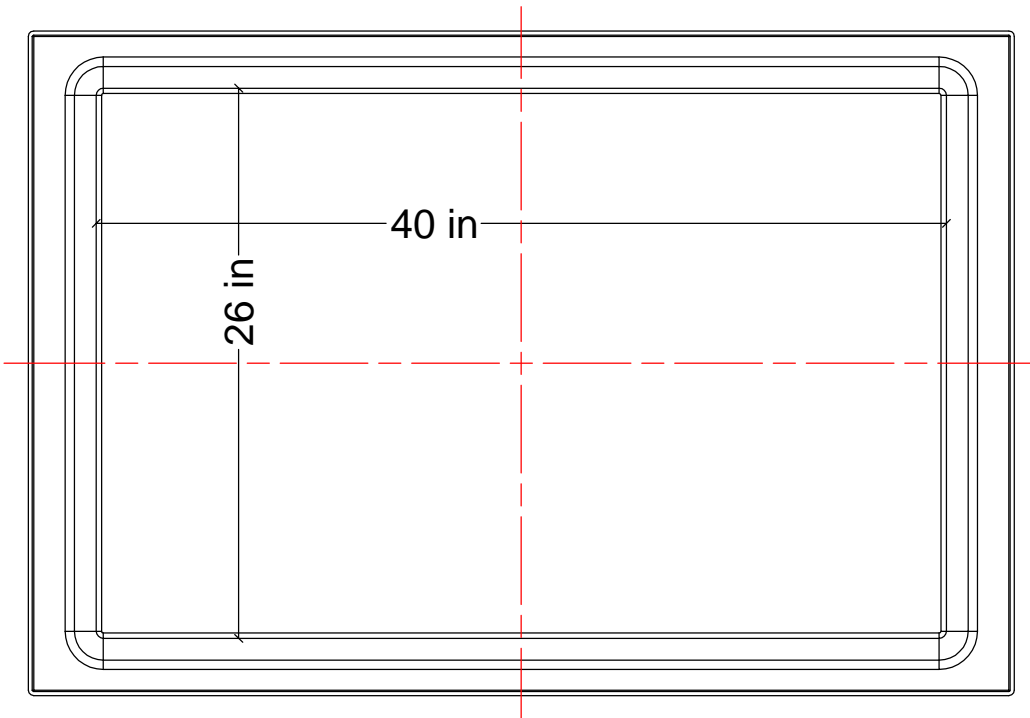

TOP VIEW

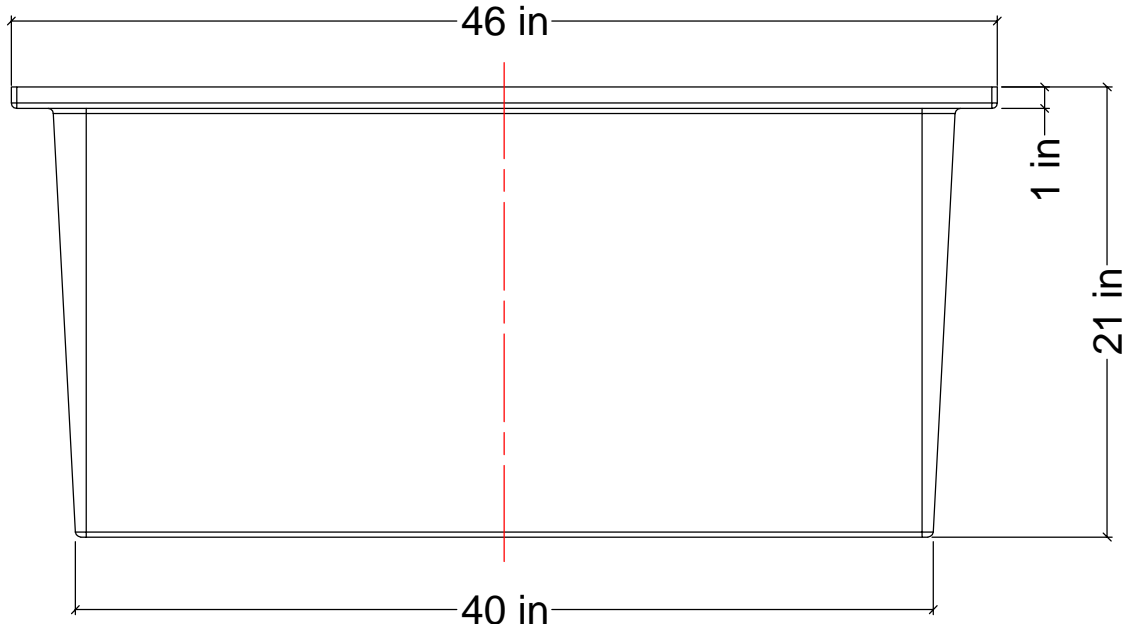
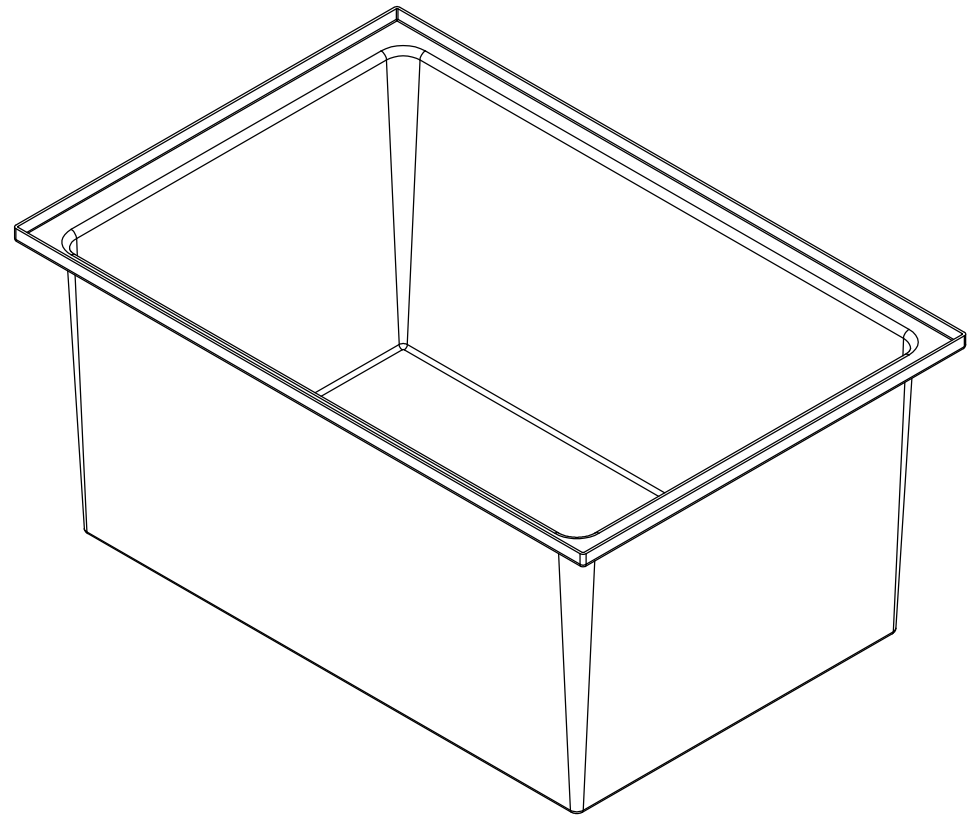

FRONT VIEW

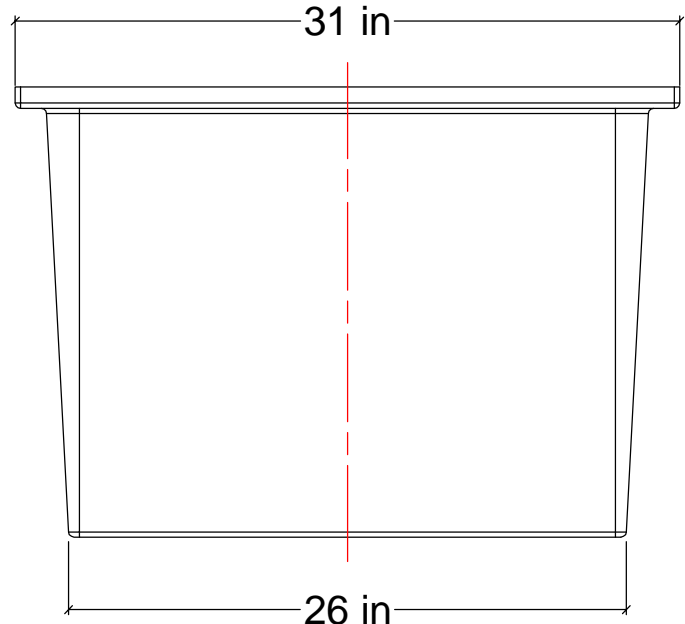

SIDE VIEW

**AGRICO PLASTIQUES**  
 450-471-2772  
[WWW.AGRICOPLASTIQUES.COM](http://WWW.AGRICOPLASTIQUES.COM)  
 RÉSERVOIR IRD90  
 CAPACITÉ DE:  
 90 GALLONS IMPÉRIAUX  
 108 GALLONS US  
 409 LITRES