

RESERVOIR HORIZONTAL AUTOPORTANT DE 5025 GALLONS US

WWW.AGRICO-PLASTIQUES.COM

REVISIONS				
ZONE	REV	DESCRIPTION	DATE	APPROVED

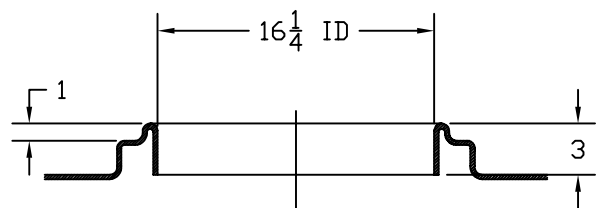
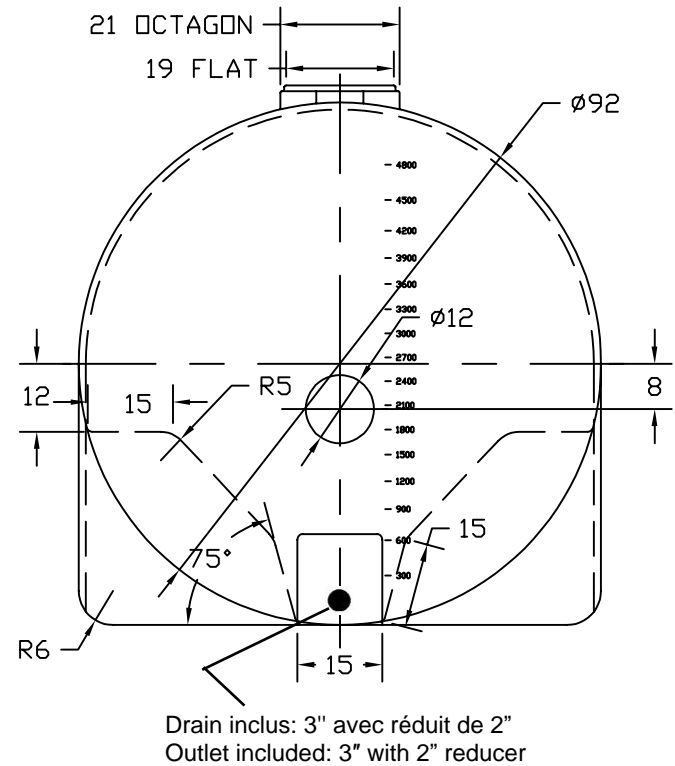
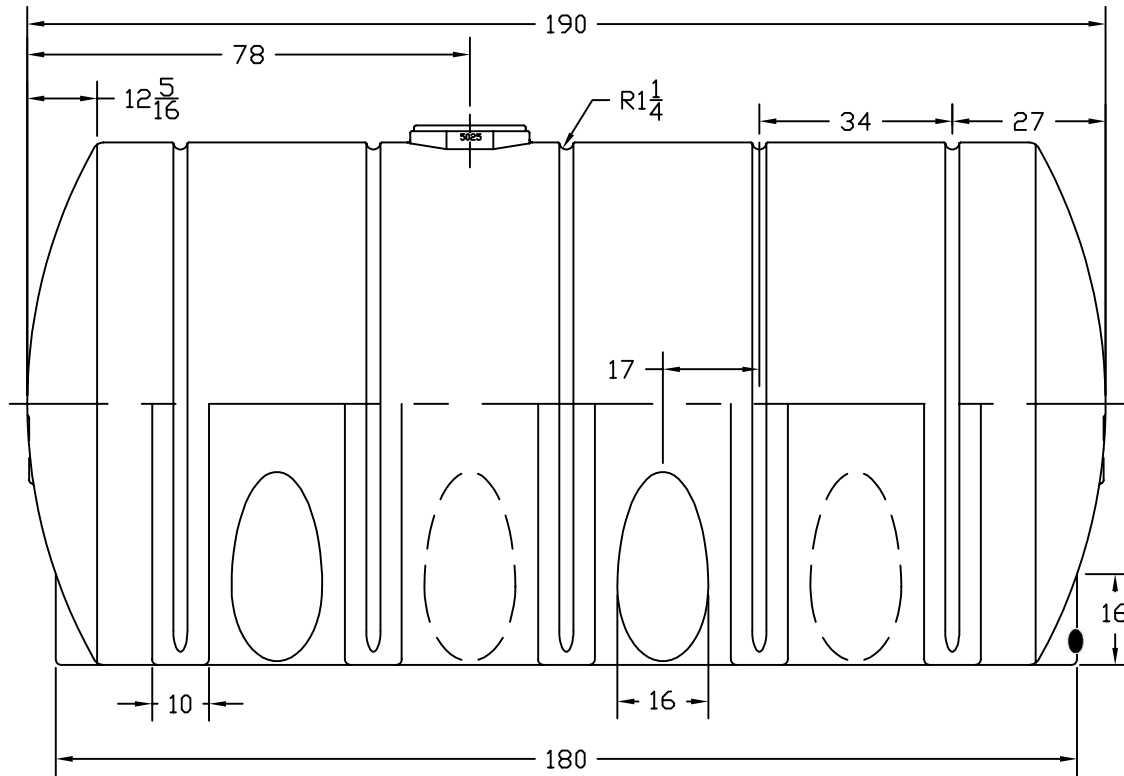

FILLWELL DETAIL - 1/8" SCALE

HL-41879	AGRICO PLASTIQUES 450-471-2772		
	5025 HORIZONTAL LEG TANK		
JTP	04AUG03	SIZE B	FSCM NO.
		DWG NO.	REV
SCALE 1/24		SHEET	